

BRITISH STANDARD

**Methods of test for
assessment of the ignitability
of mattresses, upholstered
divans and upholstered bed
bases with flaming types of
primary and secondary
sources of ignition**

ICS 13.220.40; 97.140

Publishing and copyright information

The BSI copyright notice displayed in this document indicates when the document was last issued.

© BSI 2006

ISBN 0 580 47927 7

The following BSI references relate to the work on this standard:

Committee reference FW/6

Draft for comment DC05/30098212

Publication history

First published December 1986

Second edition June 1990

Third edition April 1996

Fourth edition March 2006

Amendments issued since publication

Amd. no.	Date	Text affected
-----------------	-------------	----------------------

Contents

Foreword *iii*

- 1** Scope *1*
- 2** Normative references *1*
- 3** Terms and definitions *1*
- 4** Criteria of ignition *2*
- 5** Principle *5*
- 6** Health and safety of operators *5*
- 7** Apparatus *6*
- 8** Atmosphere for conditioning and testing *8*
- 9** Mattress, upholstered divan or upholstered bed base tested with primary ignition sources *8*
- 10** Mattress, upholstered divan or upholstered bed base tested with secondary ignition sources of known bed covers (made-up bed) *13*
- 11** Final examination *19*
- 12** Test report *19*

Annexes

Annex A (informative) Example of test report layout *21*

Bibliography *22*

List of figures

- Figure 1 – Flow diagram for detection of ignition *3*
- Figure 2 – Test rig *7*
- Figure 3 – Position of ignition sources for mattress, tested alone *11*
- Figure 4 – Position of ignition sources for mattresses tested with secondary ignition sources of known bed covers *15*
- Figure A.1 – Example of test report layout *21*

List of tables

- Table 1 – Position of ignition source: mattress tested from below with primary ignition sources *9*
- Table 2 – Position of ignition source: mattress together with known bed covers, tested from below *16*

Summary of pages

This document comprises a front cover, an inside front cover, pages i to iv, pages 1 to 22, an inside back cover and a back cover.

Foreword

Publishing information

This British Standard was published by BSI and came into effect on 31 March 2006. It was prepared by Technical Committee FW/6, *Flammability performance and fire testing*. A list of organizations represented on this committee can be obtained on request to its secretary.

Supersession

This British Standard supersedes BS 6807:1996, which is withdrawn.

Relationship with other publications

This British Standard extends the range of ignition sources provided by BS EN 597-1 and BS EN 597-2. It should be read in conjunction with BS EN 597-1 and BS EN 597-2 for the complete range of primary and secondary ignition sources.

Attention is drawn to BS 7177, which specifies requirements for the resistance to ignition of mattresses, divans and bed bases in various hazard classifications, when tested in accordance with this British Standard.

Information about this document

This is a full revision of the standard. The principal change is a clarification of progressive smouldering ignition; minor editorial changes have also been made.

Tests for ignitability are usually carried out on a bare mattress, upholstered divan or upholstered bed base (see Clause 9). When different materials and products are placed together the ignitability of the composite arrangement is highly dependent on the interactions between the components. For some end uses the bed assembly is already known, e.g. barracks, married quarters, hospitals and hotels, where the specifier is responsible for all the items which make up the bed assembly. In these cases the mattress, upholstered divan or upholstered bed base and combinations thereof can be tested together with the respective bed covers (see Clause 10). The tests described in Clause 10 are intended solely for use where all the components of the complete bed assembly including sheets, etc. are known.

It cannot be assumed that protection against large flaming ignition sources will automatically give protection against smouldering ignition. It is therefore necessary to submit test specimens to both cigarette tests and flaming ignition tests.

Hazard warnings

WARNING. These tests only relate to the ignitability of the materials described in the test report [see Clause 12b) and Clause 12c)] and are not intended to reproduce the full fire hazards that might be encountered.

WARNING. This British Standard calls for the use of substances and/or procedures that can be injurious to health if adequate precautions are not taken. It refers only to technical suitability and does not absolve the user from legal obligations relating to health and safety at any stage.

Presentational conventions

The provisions of this standard are presented in roman (i.e. upright) type. Its methods are expressed either as a set of instructions or in sentences in which the principal auxiliary verb is “shall”.

Commentary, explanation and general informative material is presented in smaller italic type, and does not constitute a normative element.

Contractual and legal considerations

This publication does not purport to include all the necessary provisions of a contract. Users are responsible for its correct application.

Compliance with a British Standard cannot confer immunity from legal obligations.

Attention is drawn to the following regulations:

- Furniture and Furnishings (Fire) (Safety) Regulations 1988 [1];
- Furniture and Furnishings (Fire) (Safety) (Amendment) Regulations 1989 [2];
- Furniture and Furnishings (Fire) (Safety) (Amendment) Regulations 1993 [3];
- Control of Substances Hazardous to Health Regulations 2002 [4].

1 Scope

This British Standard describes methods for assessing the ignitability of mattresses, upholstered divans and upholstered bed bases when subjected to flaming types of primary and secondary ignition sources of differing severities.

The following methods are described:

- a) mattress, upholstered divan or upholstered bed base tested with primary ignition sources (Clause 9);
- b) mattress, upholstered divan or upholstered bed base and combinations thereof, tested with secondary ignition sources composed of known bed covers (Clause 10).

2 Normative references

The following referenced documents are indispensable for the application of this document. For dated references, only the edition cited applies. For undated references, the latest edition of the referenced document (including any amendments) applies.

BS 5852:2006, *Methods of test for assessment of the ignitability of upholstered seating by smouldering and flaming ignition sources*

BS EN 597-1:1995, *Furniture – Assessment of the ignitability of mattresses and upholstered bed bases – Part 1: Ignition source: smouldering cigarette*

BS EN 597-2:1995, *Furniture – Assessment of the ignitability of mattresses and upholstered bed bases – Part 2: Ignition source: match flame equivalent*

3 Terms and definitions

For the purposes of this British Standard, the following definitions apply.

3.1 bed

mattress placed on top of a divan or bed base (whether upholstered or not) with no other bedding items present

3.2 bed assembly

stack of successive layers of mattress and various bed covers, with or without pillow and pillowslip, representing a section through the centre of a made-up bed

3.3 bed cover

item placed on the bed by a user to provide comfort and warmth

NOTE This includes sheets, blankets, bedspreads, valances, continental quilts, quilt covers and mattress covers.

3.4 flaming

undergoing combustion in the gaseous phase with the emission of light and heat

- 3.5 ignitability**
measure of the ease with which a material, product or component can be ignited so as to flame or progressively smoulder
- 3.6 ignition sources**
- 3.6.1 ignition source**
source of energy which is used to ignite combustible materials or products
- 3.6.2 primary ignition source**
initial heat supply in a test
- 3.6.3 secondary ignition source**
combination of primary source and the effect of bed covers in a test
- 3.7 made-up bed**
bed prepared for use by covering with bed covers, tucking these between the mattress and upholstered divan or upholstered bed base, positioning pillows with pillowslips and turning down of sheets and blankets at the head end of the bed
- NOTE Individual styles vary in detail depending on the user.*
- 3.8 mattress**
upholstered product intended for sleeping upon
- 3.9 smouldering**
combustion of a material with or without the emission of light and generally evidenced by smoke and an increase in temperature but without a flame
- 3.10 progressive smouldering**
smouldering that is self-propagating, i.e. independent of the ignition source
- 3.11 ticking**
primary covering material which is not intended to be removed
- 3.12 upholstered bed base or upholstered divan**
support surface for the mattress which includes padding covered by ticking

4 Criteria of ignition

NOTE 1 The ignition sources used in this British Standard are the primary range of flaming ignition sources 2 to 7 described in BS 5852:2006 and the cigarette and match flame equivalent sources described in BS EN 597-1 and BS EN 597-2.

NOTE 2 A flow diagram illustrating a systematic method for the detection of ignition throughout a test sequence is shown in Figure 1.

Figure 1 Flow diagram for detection of ignition

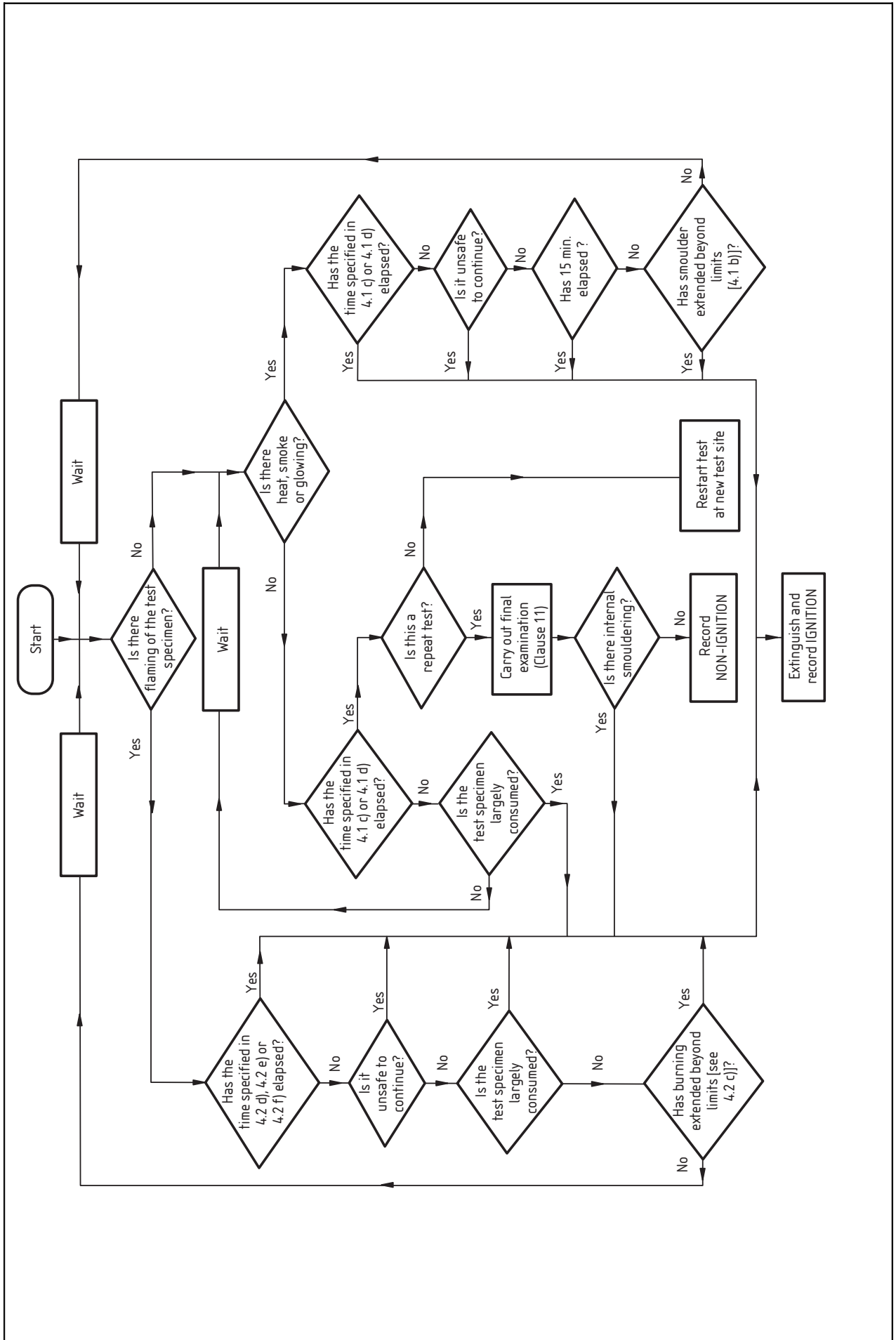

4.1 Progressive smouldering ignition

For the purposes of this British Standard all the following types of behaviour shall be deemed to be progressive smouldering ignition (but see also Clause 11):

NOTE In practice it has been found that there is usually a clear distinction between materials that smoulder and char under the influence of the ignition source but that do not propagate further (non-progressive), and those where smouldering develops in extent and spreads (progressive).

- a) any test specimen that displays escalating smouldering combustion behaviour so that it is unsafe to continue the test and forcible extinction is required;
- b) for all ignition sources: any test specimen that smoulders until it is essentially consumed or that smoulders to the extremities of the specimen, i.e. to either side or to the full thickness of the specimen, within the duration of the test;
- c) for ignition sources 2 and 3: any test specimen that produces externally detectable amounts of smoke, heat or glowing 15 min after removal of the burner tube;
- d) for ignition sources 4, 5, 6 and 7: any test specimen that produces externally detectable amounts of smoke, heat or glowing 60 min after ignition of the crib;
- e) for top ignition only: any test specimen that on final examination (see Clause 11) shows evidence of smouldering by means of discoloured char that extends more than 100 mm in any horizontal direction from the nearest part of the original position of the source.

4.2 Flaming ignition

For the purposes of this British Standard, all the following types of behaviour shall be deemed to be flaming ignition:

- a) any test specimen that displays escalating flaming combustion behaviour so that it is unsafe to continue the test and forcible extinction is required;
- b) any test specimen that burns until it is essentially consumed within the test duration;
- c) any test specimen on which any flame front reaches the extremities of the specimen other than the top or passes through the full thickness of the specimen within the duration of the test. The exception is in the case of ignition from the side or below when the flame from the source reaches the top of the specimen during the course of the test and therefore this criteria does not constitute flaming ignition;
- d) for ignition sources 2 and 3: any test specimen that continues to flame for more than 120 s after removal of the burner tube;
- e) for ignition sources 4 and 5: any test specimen that continues to flame for more than 10 min after ignition of the crib;

- f) for ignition sources 6 and 7: any test specimen that continues to flame for more than 13 min after ignition of the crib;
- NOTE The times quoted in items e) and f) are essentially 2 min greater than the upper 95% probable extinction times of wood cribs determined by interlaboratory testing.*
- g) for all sources: any test specimen from which debris causes an isolated floor fire not meeting the criteria of items d), e) or f).

5 Principle

A test specimen is subjected to a flaming ignition source placed on top of and below the test specimen.

NOTE 1 The range of intensity of the primary sources has been selected to imitate that of actual sources which might be encountered in various end use environments, while the range of intensity of the secondary sources reproduces the effects of varying amounts and types of bed covers.

NOTE 2 Ignition sources have been selected to supplement those in BS EN 597-1 and BS EN 597-2.

NOTE 3 The tests can be used to assess the ignitability at any level but it is essential that the cigarette ignition specified in BS EN 597-1 is always included.

6 Health and safety of operators

WARNING. This British Standard calls for the use of substances and/or procedures that can be injurious to health if adequate precautions are not taken. It refers only to technical suitability and does not absolve the user from legal obligations relating to health and safety at any stage.

NOTE 1 Suitable precautions might include the provision of breathing apparatus and protective clothing.

NOTE 2 Attention is drawn to the Health and Safety at Work etc. Act 1974 [5] in respect of safety precautions.

6.1 Enclosure

The tests shall be conducted in a suitable fume cupboard or purpose-built room so that individuals are not exposed to fumes (see 7.4).

6.2 Extinguishers

Readily accessible means of extinguishing the test specimens shall be provided.

NOTE 1 For preference, water should be provided for smouldering fires and a fire extinguisher for flaming fires. Carbon dioxide extinguishers are not suitable for extinguishing smouldering test specimens.

NOTE 2 Extinction of test specimens can be difficult and care should be taken that they are only disposed of when completely inert. It might be necessary to immerse smouldering specimens in water, or place them in a sealed non-combustible enclosure. To ensure complete safety other suitable steps might have to be taken.

7 Apparatus

7.1 Test rig consisting of a platform of expanded steel or open mesh supported at least 75 mm above a solid surface. If extendable legs are used, the platform shall be (380 ± 50) mm above the solid surface.

NOTE 1 The use of extendable legs is recommended where testing with ignition sources below the test specimen is specified.

The test rig shall be no smaller than the corresponding dimensions of the test specimen minus 150 mm but may be any suitable amount larger than the test specimen.

NOTE 2 A suitable test rig using extendable legs is illustrated in Figure 2.

NOTE 3 When testing a full size mattress it might be necessary to use an actual upholstered divan or upholstered bed base for ignition from below.

NOTE 4 When testing an upholstered divan or upholstered bed base it might not be necessary to use the test rig.

For ignition from below, a rectangular mesh of size (100 ± 10) mm \times (50 ± 5) mm as shown in Figure 2, and the angle iron dimensions shown in Figure 2, shall be used.

NOTE 5 The size of the mesh and the angle iron dimensions are not critical for top ignition.

For the tests, the rig shall be sited within the enclosure (see 7.4) and the testing shall be performed in a substantially draught-free environment permitting an adequate supply of air.

7.2 Stop clock accurate to 1 s.

7.3 Ignition sources as described in 9.3 and 10.3.

7.4 Test enclosure, comprising either a room with a volume greater than 20 m³ (which contains adequate oxygen for testing), or a smaller enclosure with a through-flow of air, equipped with inlet and extraction systems. Air flow rates shall be no greater than 0.2 m/s in the locality of the test specimen position.

NOTE This limit provides adequate oxygen without disturbing the burning behaviour.

7.5 Propan-2-ol.

7.6 Graduated glass syringe or other suitable measuring instrument, capable of measuring (1.4 ± 0.1) ml of propan-2-ol.

Figure 2 Test rig

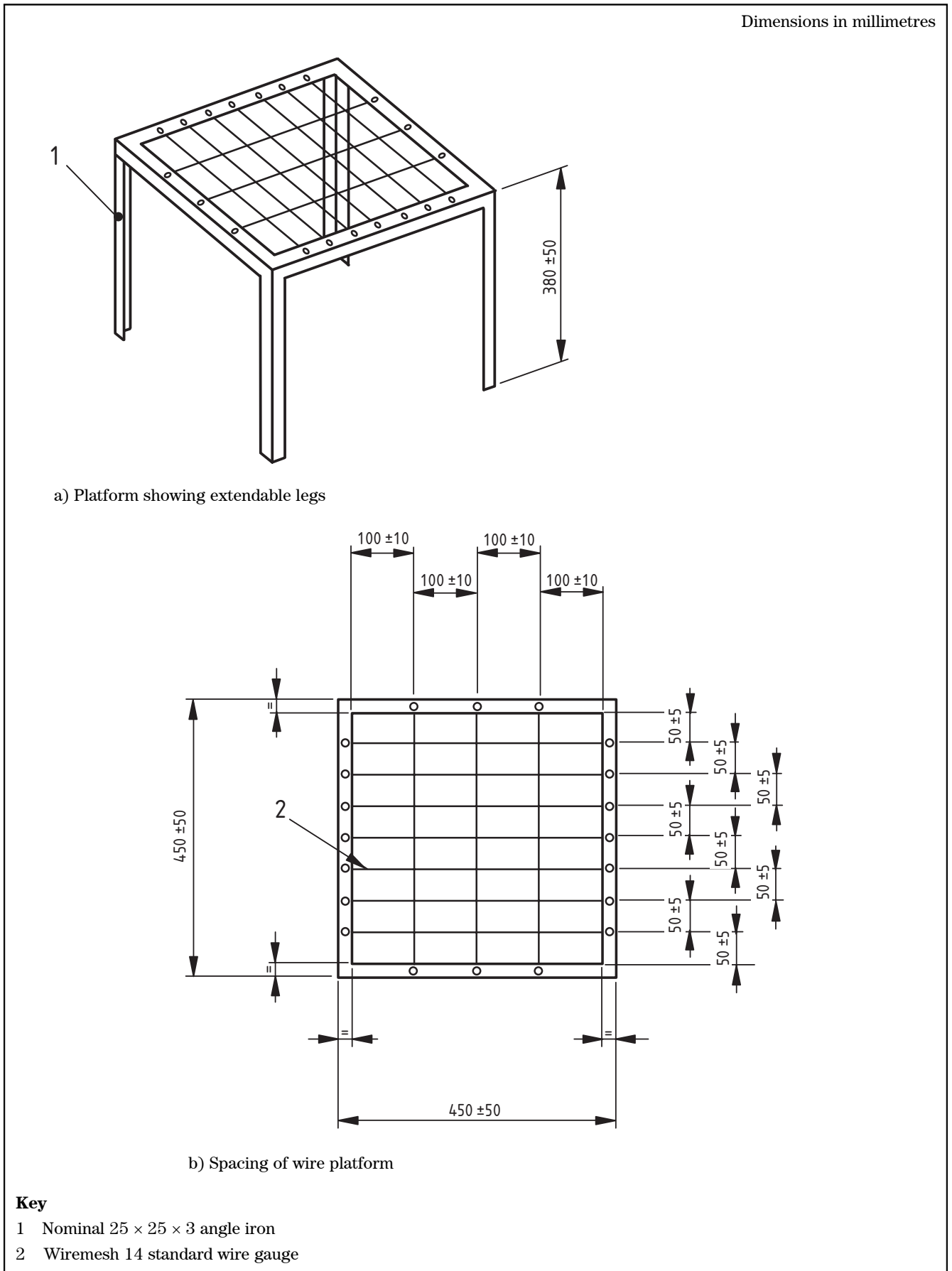

8 Atmosphere for conditioning and testing

8.1 Conditioning

The materials to be tested and the cribs shall be conditioned before the test for at least 72 h in indoor ambient conditions and then immediately before the test for at least 16 h in the following atmosphere:

- temperature: (23 ± 2) °C;
- humidity: $(50 \pm 5)\%$.

8.2 Testing

The test shall be carried out in an atmosphere having a temperature between 10 °C and 30 °C and a relative humidity of between 15% and 80%. A means of extracting smoke and toxic gases shall be provided for all such enclosures.

9 Mattress, upholstered divan or upholstered bed base tested with primary ignition sources

9.1 Principle

When mattresses, upholstered divans or upholstered bed bases are used or stored on their own it is necessary and desirable to know their ignitability in their own right (see Note 1). In this test, the item or smaller specimen is tested without bed covers or pillows present, and the ignition sources are positioned on top of and below the test specimen.

NOTE 1 The situations in which a mattress, upholstered divan or upholstered bed base might be used alone can incur the risk of exposure to more severe ignition sources than are usually encountered in domestic fires.

NOTE 2 Ignitability with respect to cigarette and simulated match sources is described in BS EN 597-1 and BS EN 597-2 respectively.

NOTE 3 The minimum source required for ignition may be different in the two arrangements (ignition sources positioned on top of and below the test specimen).

9.2 Test specimens

9.2.1 General

The test specimens shall be representative of the components and make-up of the finished item.

9.2.2 Mattress test specimen preparation

9.2.2.1 The test specimen shall be rectangular in shape and its size shall be not less than 450 mm × 350 mm × nominal thickness of the finished mattress. Representative tension shall be maintained in the ticking (see Note). The type of proposed edge finishing system shall be incorporated, e.g. plain, piped or tape edged. The proposed mattress finish shall be represented in the sample e.g. tufted, quilted or smooth-top.

NOTE Representative tension may be maintained in the ticking by means of suitable pins or clips if the test specimen is produced by cutting.

9.2.2.2 The test specimen for the upholstered divan or upholstered bed base shall consist of all the filling materials including springs or, in the case of a hard-top, including the hardboard or timber support. In the case of upholstered divans the test specimen shall where necessary be fitted with a frame to provide sufficient support for the fillings to enable the test specimen to stand unaided on the test rig.

9.2.2.3 For full size tests the actual product shall form the test specimen.

9.3 Ignition sources

9.3.1 The ignition sources to be used shall conform to sources 2 to 7 as given in BS 5852:2006.

9.3.2 When testing a mattress from below, it shall be supported on the test rig and the ignition source shall be placed at the position given in Table 1.

Table 1 **Position of ignition source: mattress tested from below with primary ignition sources**

Ignition source	Distance below mattress (<i>d</i>) ^{A)} mm
2	10 ± 1
3	15 ± 1
4	20 ± 3
5	30 ± 3
6	60 ± 3
7	100 ± 3

^{A)} For ignition sources 2 and 3 the distance given is from the upper edge of a horizontal burner tube to the lowest point of the mattress. For ignition sources 4, 5, 6 and 7 the distance given is from the top of the wooden crib to the lowest point of the mattress.

9.3.3 When testing an upholstered divan or upholstered bed base from below, the ignition source shall be placed at floor level. The lower edge of the upholstered divan or upholstered bed base shall be supported at the same height above the floor as it would be in normal use. Where there is insufficient clearance between the underside of the upholstered divan or upholstered bed base and the floor, the ignition source shall be placed adjacent to the test specimen.

9.4 Procedure

9.4.1 Sequence of tests

The sequence of tests without bed covers, using the flaming primary ignition sources 2 to 7 described in BS 5852:2006, shall be as follows:

- 2 butane gas flame;
- 3 butane gas flame;
- 4 pine wood crib;
- 5 pine wood crib;
- 6 pine wood crib;
- 7 pine wood crib.

9.4.2 Preparation

9.4.2.1 Ensure that the means of extinguishing the test specimens are close to hand (see **6.2**).

9.4.2.2 Place the test specimen on the test rig, upholstered divan or upholstered bed base and carry out the test within 5 min of removal of the test specimen from the conditioning atmosphere (see **8.1**).

9.4.3 Butane flame test: ignition sources 2 and 3

9.4.3.1 Light the butane emerging from the burner tube, adjust the gas flow to the rate given in BS 5852 and allow the flow to stabilize for at least 120 s.

9.4.3.2 Position ignition sources 2 and 3 as follows:

- a) for a test on top of the test specimen, in the position illustrated in Figure 3a);
- b) for a test below the test specimen, in the position illustrated in Figure 3a) and Figure 3b) at the distance below the test specimen given in Table 1 for mattresses, or at floor level for upholstered divans and upholstered bed bases.

9.4.3.3 Place the burner tube on top of or below the test specimen as applicable so that the flame is not less than 50 mm from any edge or marks left by any previous test, and simultaneously start the clock.

9.4.3.4 Tests shall not be carried out in coincident positions on top of and below the test specimen.

9.4.3.5 Allow the gas to burn for the time given in BS 5852 then terminate by removing the burner tube from the test specimen.

Figure 3 Position of ignition sources for mattress, tested alone

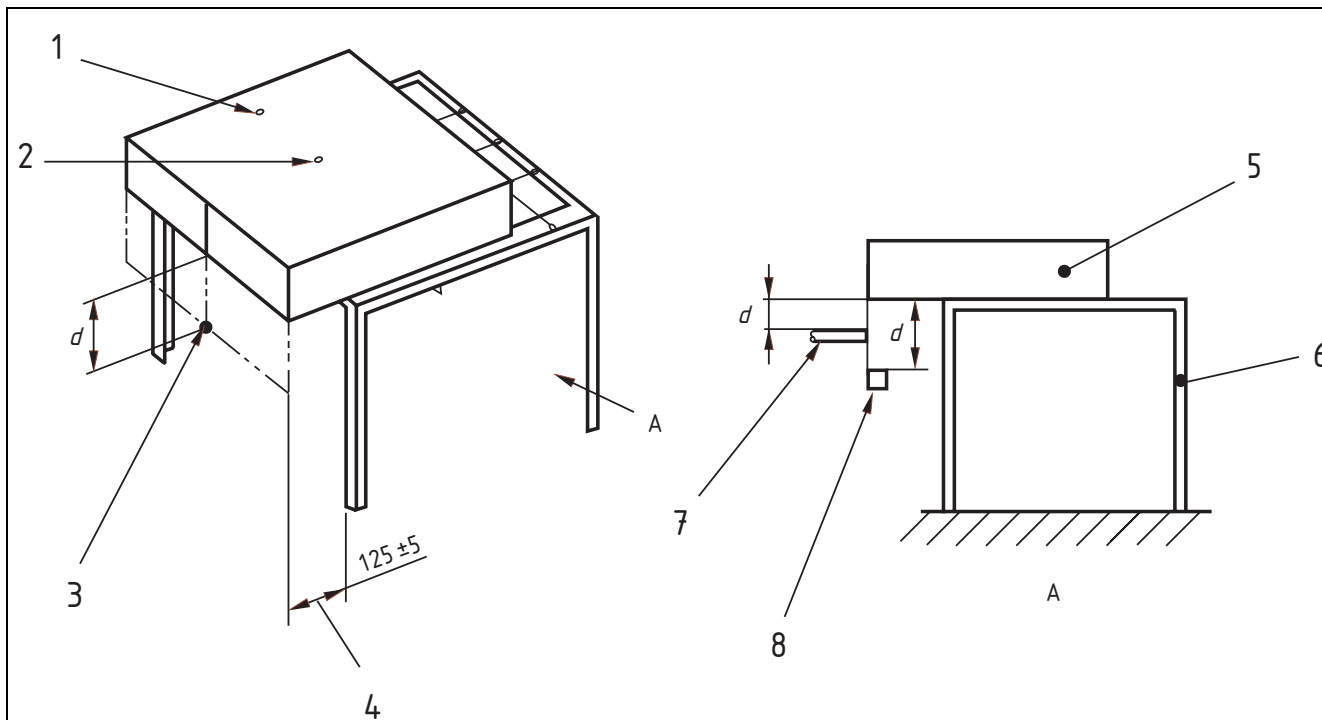

a) Test specimen using flaming ignition sources

b) Test specimen using flaming ignition sources; ignition from below (view A)

Key

- 1 Test specimen placed directly on top of rig.
Top ignition.
Ignition source placed on top of test specimen.
For ignition sources 2 and 3 at least 50 mm from any edge or marks left by any previous test.
- 2 For ignition sources 4, 5, 6 and 7 at least 170 mm from any edge or marks left by any previous test
- 3 Ignition from below.
Ignition source placed centrally between the sides of the specimen and with the leading edge of the ignition source in the same vertical plane as the specimen edge to be tested.
For distance below the test specimen d , see Table 2.
- 4 Overhang
- 5 Test specimen
- 6 Test rig
- 7 Butane gas flame ignition source
- 8 Crib ignition source

9.4.3.6 If flaming ignition (see 4.2) of the test specimen is observed, extinguish the test specimen, note the time the test was stopped and the reason, record that ignition has occurred for the ignition source used and discontinue testing.

9.4.3.7 If flaming ignition (see 4.2) is not observed, continue to observe the test site for evidence of progressive smouldering ignition (see 4.1). If progressive smouldering ignition is observed, extinguish the test specimen, note the time the test was stopped and the reason, record that ignition has occurred for the ignition source used and discontinue testing.

9.4.3.8 If no ignition is observed, repeat the test (once only) as described in 9.4.3.2 and 9.4.3.3 using a new test position.

9.4.3.9 If flaming ignition (see 4.2) is observed on the repeat test, extinguish the test specimen, note the time the test was stopped and the reason and record that ignition has occurred for the ignition source used.

9.4.3.10 If flaming ignition (see 4.2) is not observed on the repeat test, continue to observe the test site for evidence of progressive smouldering ignition (see 4.1). If progressive smouldering ignition is observed, extinguish the test specimen, note the time the test was stopped and the reason and record that ignition has occurred for the ignition source used.

9.4.3.11 If no ignition is observed on the repeat test, record non-ignition for the ignition source unless the test specimen fails the final examination described in Clause 11. In this case, record that ignition has occurred for the ignition source used.

9.4.4 Wooden crib test: ignition sources 4, 5, 6 and 7 (pine cribs)

9.4.4.1 To the assembled crib after conditioning (see 8.1), add slowly (1.4 ± 0.1) ml of propan-2-ol to the centre of the lint using the measuring instrument (7.6). Place the crib as follows:

- a) for a test on top of the test specimen, in the position illustrated in Figure 3a) not less than 170 mm from any edge or marks left by any previous test, the distance being measured from the centre of the crib;
- b) for a test below the test specimen, in the position illustrated in Figure 3a) and Figure 3b) at the distance below the test specimen given in Table 2 for mattresses, or at floor level for upholstered divans and upholstered bed bases.

9.4.4.2 Tests shall not be carried out in coincident positions on top of and below the test specimen.

9.4.4.3 Within 2 min of adding the propan-2-ol, ignite the lint using a match, small gas flame or hot wire, and simultaneously start the clock. If the crib fails to ignite, repeat the test with a new crib placed as described in 9.4.4.1.

9.4.4.4 Examine the test specimen closely and record the time from ignition of the crib to extinction of the specimen.

NOTE Apparent extinction should be checked by closer examination, which might entail entering the test enclosure.

9.4.4.5 If flaming ignition (see 4.2) of the test specimen is observed, extinguish the test specimen, note the time the test was stopped and the reason, record that ignition has occurred for the ignition source used and discontinue testing.

9.4.4.6 If flaming ignition (see 4.2) is not observed, continue to observe the test site for evidence of progressive smouldering ignition (see 4.1). If progressive smouldering ignition is observed, extinguish the test specimen, note the time the test was stopped and the reason, record that ignition has occurred for the ignition source used and discontinue testing.

9.4.4.7 If no ignition is observed, repeat the test (once only) as described in 9.4.4.1 to 9.4.4.4.

NOTE If a full-size item is used for this test and space allows, this repeat test may be run concurrently with the first test.

9.4.4.8 If flaming ignition (see 4.2) is observed on the repeat test, extinguish the test specimen, note the time the test was stopped and the reason and record that ignition has occurred for the ignition source used.

9.4.4.9 If flaming ignition (see 4.2) is not observed on the repeat test, continue to observe the test site for evidence of progressive smouldering ignition (see 4.1). If progressive smouldering ignition is observed, extinguish the test specimen, note the time the test was stopped and the reason and record that ignition has occurred for the ignition source used.

9.4.4.10 If no ignition is observed on the repeat test, record non-ignition for the ignition source unless the test specimen fails the final examination described in Clause 11. In this case, record that ignition has occurred for the ignition source used.

10 Mattress, upholstered divan or upholstered bed base tested with secondary ignition sources of known bed covers (made-up bed)

10.1 Principle

When the total bed assembly is known, the most effective tests are those that reproduce these details exactly (see Note). In this test, the bed covers and pillows are used as a secondary source to which the primary ignition sources are applied, commencing with ones of low severity. The intensity is then increased until ignition occurs. The primary source is positioned on top of and below the test assembly, but the minimum source required for ignition might be different in the two arrangements.

NOTE This situation applies mainly to mattresses, upholstered divans or upholstered bed bases not sold in the retail trade, i.e. for contract use.

The mattress is supported either on a test rig or on the upholstered divan or upholstered bed base.

10.2 Test specimens

10.2.1 General

The test specimens shall be representative of the components and make-up of the finished bed assembly, including the order in which bed covers are laid on the mattress.

10.2.2 Mattress test specimen preparation

The test specimen shall be rectangular in shape and its size shall be not less than 1 m × nominal width of the mattress × nominal thickness of the finished mattress. Representative tension shall be maintained in the ticking (see Note). The type of proposed edge finishing system shall be incorporated, e.g. plain, piped or tape edged. The proposed mattress finish shall be represented in the sample, e.g. tufted, quilted or smooth-top.

NOTE Representative tension may be maintained in the ticking by means of suitable pins or clips if the test specimen is produced by cutting.

10.2.3 Bed assembly

The mattress test specimen shall be as described in **10.2.2** and the bed covers shall be of sufficient size to allow for a tuck-in between the mattress and either the test rig or the upholstered divan or upholstered bed base, or to leave an overhang (see Figure 4).

Figure 4 Position of ignition sources for mattresses tested with secondary ignition sources of known bed covers

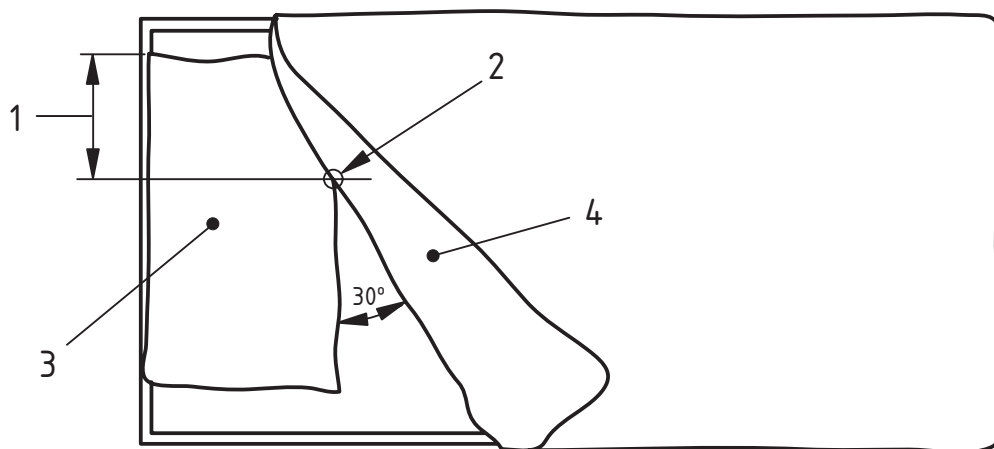

a) Plan

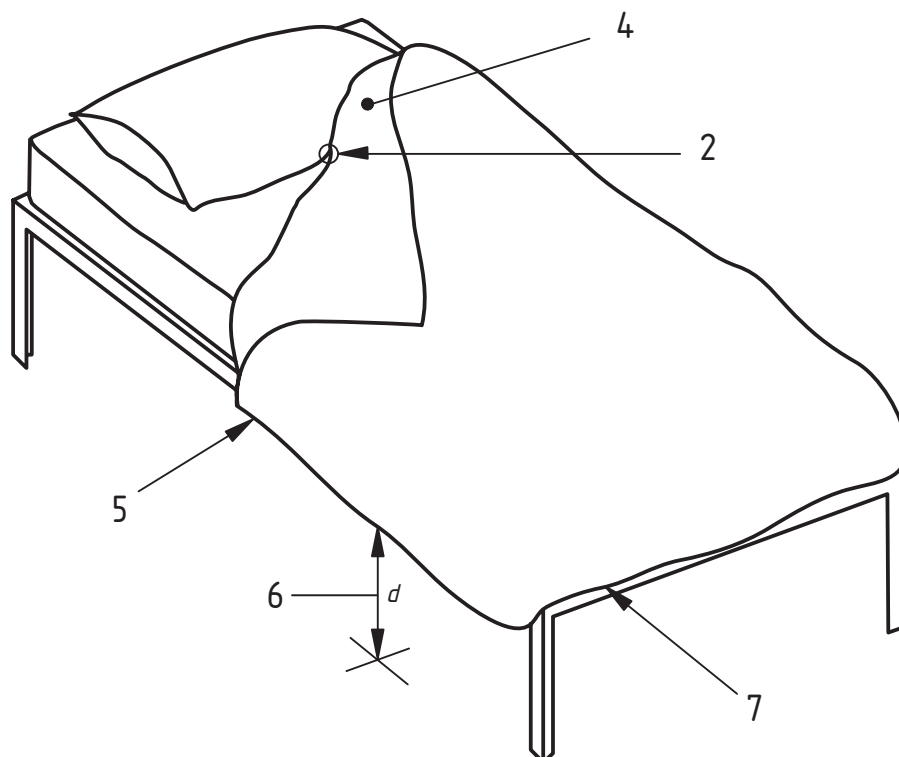

b) Perspective view

Key

- 1 One-third length of pillow (approx.)
- 2 Ignition source placed at junction of pillow and folded back bedcovers
- 3 Pillow
- 4 Bed covers folded back at an angle of 30° to the pillow (see Note 1 to 10.4.2.3)
- 5 Bed covers overhang beneath the bottom edge of the test rig (70 ± 5 mm)
- 6 Ignition source placed directly under and in line with overhang of bed covers (for distance below test specimen, see Table 2)
- 7 Bed covers tucked between mattress and test rig, upholstered divan or upholstered bed base to be level with edge

10.3 Ignition sources

10.3.1 The ignition sources to be used shall conform to sources 2 to 7 as given in BS 5852:2006, Clause 9.

10.3.2 When testing a bed assembly from below it shall be supported on the test rig and the ignition source shall be placed at the position given in Table 2.

Table 2 **Position of ignition source: mattress together with known bed covers, tested from below**

Ignition source	Distance below mattress (<i>d</i>) ^{A)} mm
Match flame equivalent	5 ± 1
2	10 ± 1
3	15 ± 1
4	20 ± 3
5	30 ± 3
6	60 ± 3
7	100 ± 3

^{A)} For ignition sources 2 and 3 the distance given is from the upper edge of the horizontal burner tube to the lowest point of the mattress. For ignition sources 4, 5, 6 and 7 the distance given is from the top of the wooden crib to the lowest point of the mattress.

10.3.3 When testing an upholstered divan or upholstered bed base from below in the presence of the bed assembly, the ignition source shall be placed at floor level. The lower edge of the upholstered divan or upholstered bed base shall be supported at the same height above the floor as it would be in normal use. Where there is insufficient clearance between the underside of the upholstered divan or upholstered bed base and the floor, the ignition source shall be placed adjacent to the test specimen.

10.4 Procedure

10.4.1 Sequence of tests

The sequence of tests with known bed covers as secondary ignition sources shall be as follows:

- smouldering cigarette plus known bed covers;
- match flame equivalent plus known bed covers;
- 2 butane gas flame plus known bed covers;
- 3 butane gas flame plus known bed covers;
- 4 pine wood crib plus known bed covers;
- 5 pine wood crib plus known bed covers;
- 6 pine wood crib plus known bed covers;
- 7 pine wood crib plus known bed covers.

The smouldering cigarette and match flame equivalent sources shall be as described in BS EN 597-1 and BS EN 597-2. The flaming primary ignition sources 2 to 7 shall be as described in BS 5852:2006.

10.4.2 Preparation

10.4.2.1 Ensure that the means of extinguishing the test specimens are close to hand (see **6.2**).

10.4.2.2 Place the mattress test specimen on the test rig, upholstered divan or upholstered bed base, and carry out the test within 5 min of removal of the test specimen from the conditioning atmosphere (see **8.1**).

10.4.2.3 Place the bed covers on top of the mattress in the order they would be used, allowing an overhang of (70 ± 5) mm on one side beneath the bottom edge of the frame, upholstered divan or upholstered bed base. Leave the bottom sheet in position and turn back the remainder of the bed covers as illustrated in Figure 4.

NOTE 1 It is known that minor variations in the assembly of the test specimen, e.g. the tightness of bedding folds, can exert a major influence on test results. Care is necessary in preparing the test specimen and the use of a template is recommended as an aid to specimen assembly.

NOTE 2 Details of the construction of the bed assembly are required in the test report [see Clause 12b)].

10.4.3 Butane flame test: ignition sources 2 and 3

10.4.3.1 Light the butane emerging from the burner tube, adjust the gas flow to the rate given in BS 5852 and allow the flow to stabilize for at least 120 s.

10.4.3.2 Unless otherwise specified (see **10.3.3**), position ignition sources 2 and 3 as follows:

- a) for a test on top of the test specimen, in the position illustrated in Figure 4;
- b) for a test below the test specimen, in the position illustrated in Figure 4 at the distance below the test specimen given in Table 2 with the centreline of the ignition source directly in line with the overhang of the bed covers.

10.4.3.3 Place the burner tube on top of or below the test specimen as applicable so that the flame is not less than 50 mm from any marks left by any previous test, and simultaneously start the clock.

10.4.3.4 Tests shall not be carried out in coincident positions on top of and below the test specimen.

10.4.3.5 Allow the gas to burn for the time given in BS 5852 then terminate by removing the burner tube from the test specimen.

10.4.3.6 If flaming ignition (see **4.2**) of the test specimen is observed, extinguish the test specimen, note the time the test was stopped and the reason, record that ignition has occurred for the ignition source used and discontinue testing.

10.4.3.7 If flaming ignition (see **4.2**) is not observed, continue to observe the test site for evidence of progressive smouldering ignition (see **4.1**). If progressive smouldering ignition is observed, extinguish the test specimen, note the time the test was stopped and the reason, record that ignition has occurred for the ignition source used and discontinue testing.

10.4.3.8 If no ignition is observed, repeat the test (once only) as described in **10.4.3.2** and **10.4.3.3** using a new test position.

10.4.3.9 If flaming ignition (see **4.2**) is observed on the repeat test, extinguish the test specimen, note the time the test was stopped and the reason and record that ignition has occurred for the ignition source used.

10.4.3.10 If flaming ignition (see **4.2**) is not observed on the repeat test, continue to observe the test site for evidence of progressive smouldering ignition (see **4.1**). If progressive smouldering ignition is observed, extinguish the test specimen, note the time the test was stopped and the reason and record that ignition has occurred for the ignition source used.

10.4.3.11 If no ignition is observed on the repeat test, record non-ignition for the ignition source unless the test specimen fails the final examination described in Clause **11**. In this case, record that ignition has occurred for the ignition source used.

10.4.4 Wooden crib test: ignition sources 4, 5, 6 and 7 (pine cribs)

10.4.4.1 To the assembled crib, after conditioning (see **8.1**), add slowly (1.4 ± 0.1) ml of propan-2-ol to the centre of the lint. Place the crib as follows:

- a) for a test on top of the test specimen, in the position illustrated in Figure 4;
- b) for a test below the test specimen, in the position illustrated in Figure 4 at the distance below the test specimen given in Table 2 with the centreline of the ignition source directly in line with the overhang of the bed covers.

10.4.4.2 Tests shall not be carried out in coincident positions on top of and below the test specimen.

10.4.4.3 Within 2 min of adding the propan-2-ol, ignite the lint using a match, small gas flame or hot wire, and simultaneously start the clock. If the crib fails to ignite, repeat the test with a new crib placed as described in **10.4.4.1**.

10.4.4.4 Examine the test specimen closely and record the time from ignition of the crib to extinction of the specimen.

10.4.4.5 If flaming ignition (see **4.2**) of the test specimen is observed, extinguish the test specimen, note the time the test was stopped and the reason, record that ignition has occurred for the ignition source used and discontinue testing.

10.4.4.6 If flaming ignition (see 4.2) is not observed, continue to observe the test site for evidence of progressive smouldering ignition (see 4.1). If progressive smouldering ignition is observed, extinguish the test specimen, note the time the test was stopped and the reason, record that ignition has occurred for the ignition source used and discontinue testing.

10.4.4.7 If no ignition is observed, repeat the test as described in 10.4.4.1 to 10.4.4.4 using a new test position.

10.4.4.8 If flaming ignition (see 4.2) is observed on the repeat test, extinguish the test specimen, note the time the test was stopped and the reason and record that ignition has occurred for the ignition source used.

10.4.4.9 If flaming ignition (see 4.2) is not observed on the repeat test, continue to observe the test site for evidence of progressive smouldering ignition (see 4.1). If progressive smouldering ignition is observed, extinguish the test specimen, note the time the test was stopped and the reason and record that ignition has occurred for the ignition source used.

10.4.4.10 If no ignition is observed on the repeat test, record non-ignition for the ignition source unless the test specimen fails the final examination described in Clause 11. In this case, record that ignition has occurred for the ignition source used.

NOTE Apparent extinction should be checked by closer examination, which might entail entering the test enclosure.

11 Final examination

Since progressive smouldering ignition undetected from the outside might occur, dismantle the test specimen immediately after completion of the test programme and examine it internally for smouldering ignition. If this is present, extinguish the test specimen and record that ignition has occurred for the relevant ignition source. For safety reasons ensure that all smouldering ignition has ceased before the test rig is left unattended.

12 Test report

The test report shall state:

- a) “The following test results relate only to the ignitability of the combination of materials under the particular condition of test; they are not intended as a means of assessing the full potential fire hazard of the item in use”;
- b) the identification of the item and any other components and the construction of the bed assembly;

NOTE 1 Unless a test report contains sufficient information about the materials and constructions tested to identify them precisely and any flame retardant treatment, it might be of only limited value to a third party such as a purchaser, fire authority or law enforcement officer.

- c) each ignition source applied, and the test result: ignition or non-ignition;
- d) the number and clause of this British Standard, i.e. BS 6807:2006, Clause **9**, or BS 6807:2006, Clause **10**.

The test report shall contain details of any features of the test specimens or procedures that might have affected the results. Such features are:

- 1) conditioning of the test specimen, including precleansing if applicable;
- 2) special features of burning, e.g. melting, dripping, charring, development of flames from smouldering;
- 3) times of major events, e.g. ignition of test specimens, initiation of smoking and/or flaming in the test specimen, ticking splitting, extinction.

NOTE 2 An example of a test report layout is shown in Annex A.

Annex A (informative) Example of test report layout

Figure A.1 shows an example of a test report layout.

NOTE 1 The position of the ignition source should be indicated under the headings for Ignition source, Number and Position at the bottom of Figure A.1, e.g. "5T" (on top) and "5B" (below). Where testing has been undertaken both on top of and below the test specimen two entries are needed.

NOTE 2 Any events worthy of note but not included in the comments column should be recorded within the test report.

Figure A.1 Example of test report layout

Testing authority											
Test number											
Test specimen reference											
Company/customer											
Date											
British Standard BS 6807:2006											
Clause 9 (primary ignition sources)/Clause 10 (secondary ignition sources) ^{A)}											
Ignition sources used											
Test conditions			Period h		Temperature °C			Relative humidity %		Volume m ³	
Conditioning of test specimen and ignition sources(s)											
Test enclosure											
Materials tested											
			Width mm		Length mm			Depth mm			
Dimensions of test specimen											
Report											
The following test results relate only to the ignitability of the combination of materials under the particular conditions of test.											
They are not intended as a means of assessing the full potential fire hazard of this item in use.											
Ignition source		Ignition/ non- ignition	Time to extinction			Extent of damage			Date of test	Comments	
Number	Position		of ignition min	of flame min	of smoke min	Width mm	Length mm	Depth mm			
^{A)} Delete as applicable.											

Bibliography

Standards publications

For dated references, only the edition cited applies. For undated references, the latest edition of the referenced document (including any amendments) applies.

BS 7177, *Specification for resistance to ignition of mattresses, divans and bed bases*

Other publications

- [1] GREAT BRITAIN. Furniture and Furnishings (Fire) (Safety) Regulations 1988. London: HMSO.
- [2] GREAT BRITAIN. Furniture and Furnishings (Fire) (Safety) (Amendment) Regulations 1989. London: HMSO.
- [3] GREAT BRITAIN. Furniture and Furnishings (Fire) (Safety) (Amendment) Regulations 1993. London: HMSO.
- [4] GREAT BRITAIN. Control of Substances Hazardous to Health Regulations 2002. London: The Stationery Office.
- [5] GREAT BRITAIN. Health and Safety at Work etc. Act 1974. London: HMSO.

BSI – British Standards Institution

BSI is the independent national body responsible for preparing British Standards. It presents the UK view on standards in Europe and at the international level. It is incorporated by Royal Charter.

Revisions

British Standards are updated by amendment or revision. Users of British Standards should make sure that they possess the latest amendments or editions.

It is the constant aim of BSI to improve the quality of our products and services. We would be grateful if anyone finding an inaccuracy or ambiguity while using this British Standard would inform the Secretary of the technical committee responsible, the identity of which can be found on the inside back cover.

Tel: +44 (0)20 8996 9000. Fax: +44 (0)20 8996 7400.

BSI offers members an individual updating service called PLUS which ensures that subscribers automatically receive the latest editions of standards.

Buying standards

Orders for all BSI, international and foreign standards publications should be addressed to Customer Services. Tel: +44 (0)20 8996 9001.

Fax: +44 (0)20 8996 7001. Email: orders@bsi-global.com. Standards are also available from the BSI website at <http://www.bsi-global.com>.

In response to orders for international standards, it is BSI policy to supply the BSI implementation of those that have been published as British Standards, unless otherwise requested.

Information on standards

BSI provides a wide range of information on national, European and international standards through its Library and its Technical Help to Exporters Service. Various BSI electronic information services are also available which give details on all its products and services. Contact the Information Centre. Tel: +44 (0)20 8996 7111. Fax: +44 (0)20 8996 7048. Email: info@bsi-global.com.

Subscribing members of BSI are kept up to date with standards developments and receive substantial discounts on the purchase price of standards. For details of these and other benefits contact Membership Administration. Tel: +44 (0)20 8996 7002. Fax: +44 (0)20 8996 7001. Email: membership@bsi-global.com.

Information regarding online access to British Standards via British Standards Online can be found at <http://www.bsi-global.com/bsonline>.

Further information about BSI is available on the BSI website at <http://www.bsi-global.com>.

Copyright

Copyright subsists in all BSI publications. BSI also holds the copyright, in the UK, of the publications of the international standardization bodies. Except as permitted under the Copyright, Designs and Patents Act 1988 no extract may be reproduced, stored in a retrieval system or transmitted in any form or by any means – electronic, photocopying, recording or otherwise – without prior written permission from BSI.

This does not preclude the free use, in the course of implementing the standard, of necessary details such as symbols, and size, type or grade designations. If these details are to be used for any other purpose than implementation then the prior written permission of BSI must be obtained.

Details and advice can be obtained from the Copyright & Licensing Manager.

Tel: +44 (0)20 8996 7070. Fax: +44 (0)20 8996 7553.

Email: copyright@bsi-global.com.